

205

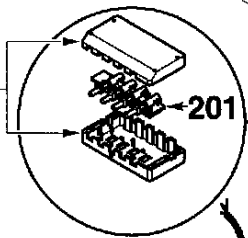

201

231

227

230

232

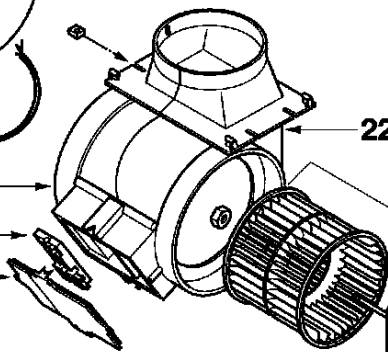

226

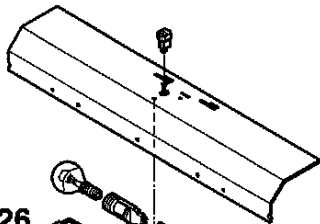

276

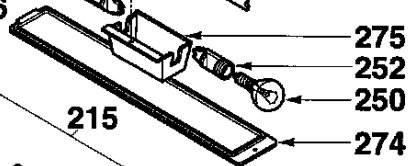

275

252

250

274

215

